

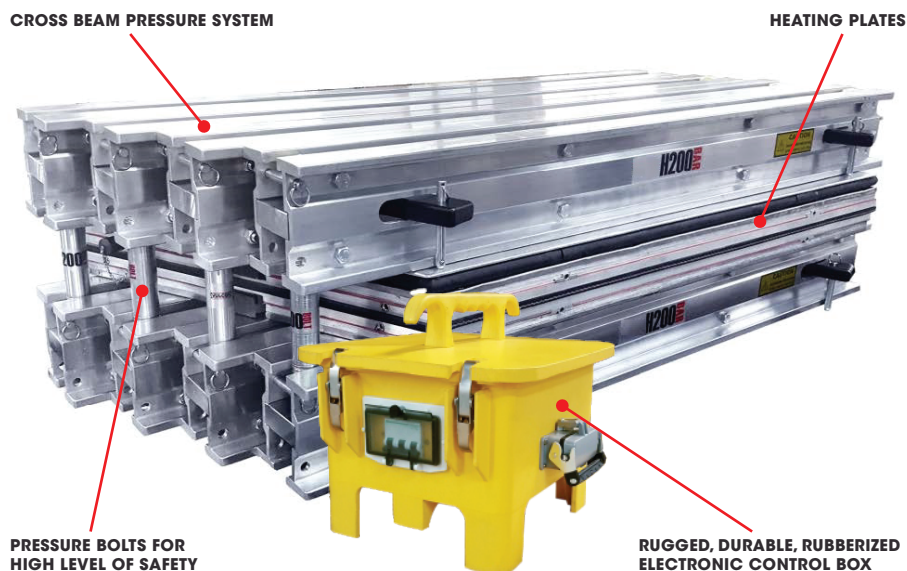

SHELRON VULCANIZING PRESSES are light weight, durable and versatile with complete availability of coverage for all splice lengths, fabric ply or steel cord.

Our presses are easy to set-up and operate and easy to maintain. Shelron Vulcanizing Presses are made of high grade aluminum platens and beams to provide maximum tensile and bending strength with minimum weight.

All Shelron Vulcanizing Presses provide uniform temperature and pressure required to vulcanize a wide array of conveyor belts. We manufacture to all sizes and have a stock of the more traditional sizes used in the industry.



FEATURES AND BENEFITS:

- Lightweight compact design for easy transport
- Includes flush valves and inset bolts/nuts connecting the traverse bars
- All electrical systems are CE, CSA and UL approved
- Durable for use in harshest of environments
- Pressure bolts pass through the cross beam profile for a high level of safety
- Exact temperature regulation via an electronic control box
- Even pressure distribution across the splice area.
- Vulcanizing temperature is uniform and accurate.
- Automatic features for setting the temperature and curing time
- Standard sizes are available (custom size upon request)

VULCANIZING PRODUCTS

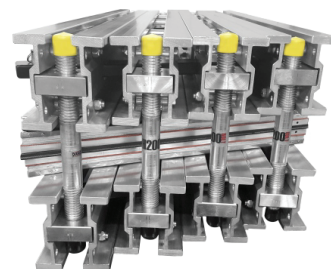

Pressure bolts for high level of safety



Rubber pressure bag for even distribution



Electronic control box with data logger for regulating temperature

ELECTRONIC CONTROL BOX SYSTEM WITH ELECTRONIC TEMPERATURE CONTROL SYSTEM

- Exact temperature reading in each heating plate via thermo-sensor PT 100
- Electrical connection as per CE, CSA and UL standards
- Quick and simple programming of the electronic temperature control
- Differential monitoring of the individual heating circuits
- Each control box can operate one set of platens



COMPONENTS/SPECIFICATIONS

- **Platen** - Custom extruded plank, silicone heating elements (up to 163°C/325°F), and durable composite insulating packaging are used to construct a flexible platen that contours to belt irregularities. Flush connectors provide a smooth profile; recessed power connections are sealed for moisture resistance.
- **Beam Restraining System** - Superior H-Style bars made of extruded aluminum are engineered for any belt width. Recessed high tensile steel nut/bolt assemblies connect H-Style bars for a steadfast, reduced profile. Each press includes a restraining system as a secondary H-bar lock for increased operator safety.
- **Control Box** - The new Switchgear Box is the most advanced control system in the world. Incorporating controls for 2 platens. Splice data can be stored and recalled through the built in data logger.
- **CE, CSA and UL Approved** – All electrical CE, CSA and UL approved

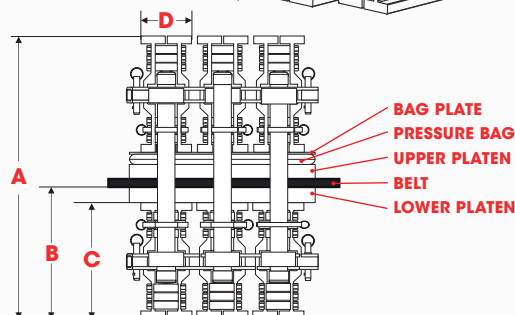
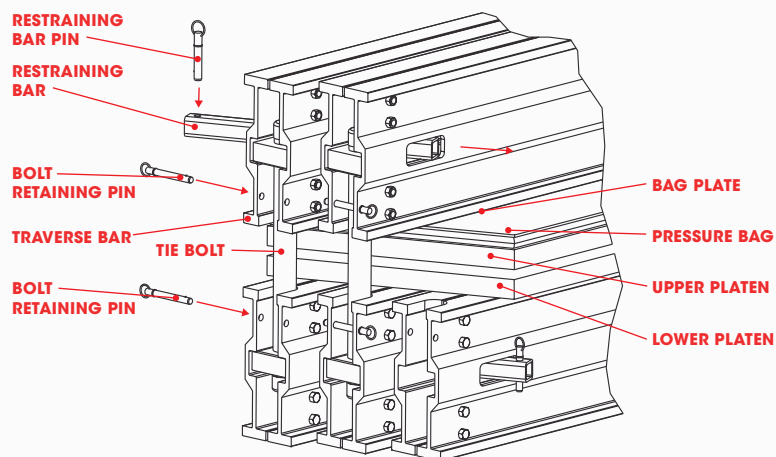

TRAVERSE BARS AVAILABLE SIZES

BARS	A		B		C		D	
	in	mm	in	mm	in	mm	in	mm
H200	22	559	10	248	8	197	7	178
H270	28	699	13	318	11	267	7	178
H330	33	826	13	381	12	330	6	152
H380	37	927	17	432	15	381	6.4	165
H430	39	1010	19	480	17	431	8.7	223

DETAILS

- **Material:** High Grade Aluminium
- **Control Box:** Automatic process
- **Ammeter**
- **Heating:** Electric shielded resistance or silicone elements
- **Cooling:** Water or air cooled
- **Power Voltage:** 220V, 380V, 400V, 415V, 440V, 480V, 525V or any other on request
- **Vulcanizing Temperature:** Adjustable between 0~200°C (392°F)

- A.** Splice Length
 - B.** Belt Width
 - C.** Length of platen along the belt
 - D.** Width of the platen square to belt line
 - E.** Bias Angle
 - F.** Width of platen along the belt on bias
- C.** The platen length (**C**) is calculated by adding to the belt manufacturer's recommended splice length.
6" inches (150mm) for fabric belt
14" inches (355mm) for steel cord belt
- D.** The platen width (**D**) is determined by adding to the belt width.
6" inches (150mm) for fabric belt
8" inches (200mm) for steel cord belt
- F.** Width of the platen along the belt on bias.

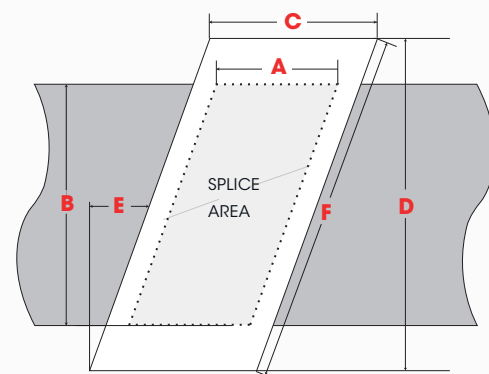

TO FIGURE THIS MULTIPLY BY:
1.07 for 22° degree bias angle
1.05 for 17° degree bias angle

Dimensions **C** and **D** represent the outside platen dimensions. Custom sizes, rectangular configurations and multiple platen arrangements are also available upon request.

AVAILABLE REPLACEMENT COMPONENTS:

1. Control Box With Data Logger
2. Platen Cords
3. Pressure Bag



1



2



3